

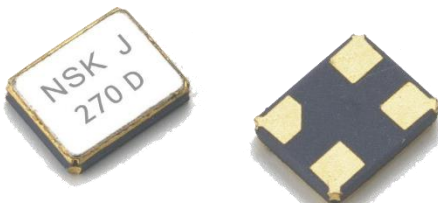











## NXN Series 2.0 x 1.6

  	<b>Application :</b> <ul style="list-style-type: none"> <li> Office automation equipment</li> <li> Audio-visual equipment</li> <li> Radio communication</li> <li> GPS</li> </ul>
	<b>Features :</b> <ul style="list-style-type: none"> <li> Packing in embossed carrier tape realize auto SMT</li> <li> Excellent vibration resistance &amp; shock resistance</li> <li> RoHS compliant / Pb free</li> <li> Excellent solderability</li> <li> Seam welding</li> </ul>

## Electrical Specification :

Model	NXN-21
<b>1. Frequency</b>	
Frequency Range	12.0 ~ 96.0 MHz
Frequency Tolerance at 25°C±2°C	±10 ~ ±50 ppm (TYP.)
Frequency Stability Over Operating Temp Range	±10 ~ ±50 ppm (TYP.)
<b>2. Environmental Condition</b>	
Operating Temp Range	-10°C~ +60°C, -20°C~ +70°C or specify
Storage Temp Range	-40°C ~ +125°C
Aging Rate	±3ppm/year
<b>3. Electrical Specifications</b>	
Test Circuit	S&A 250B
Load Capacitance	6pF ~ 32pF, series or specify
Drive Level	1uW ~ 100uW or specify
Shunt Capacitance	3.0pF max

\* Above specification subject to change without prior notice, please consult our sales representative for more information\*

SHENZHEN - Shenzhen Huilicheng Electronic Technology Co.,Ltd. HONGKONG - HUILICHENG ELECTRONICS(HK)CO.,LIMITED

Address: 6910b,Seg Plaza,No.1002 North Huaqiang Road,Fuqiang Community,Huaqiang North Street,Shenzhen,Guangdong,China

Tel: +86-0755-83576022

E-mail: hlc-zzw@hlcdzjk.com

Fax: 0755-83778079

Web: <http://www.hlcdzjk.com>



## Tape Specification(mm) :

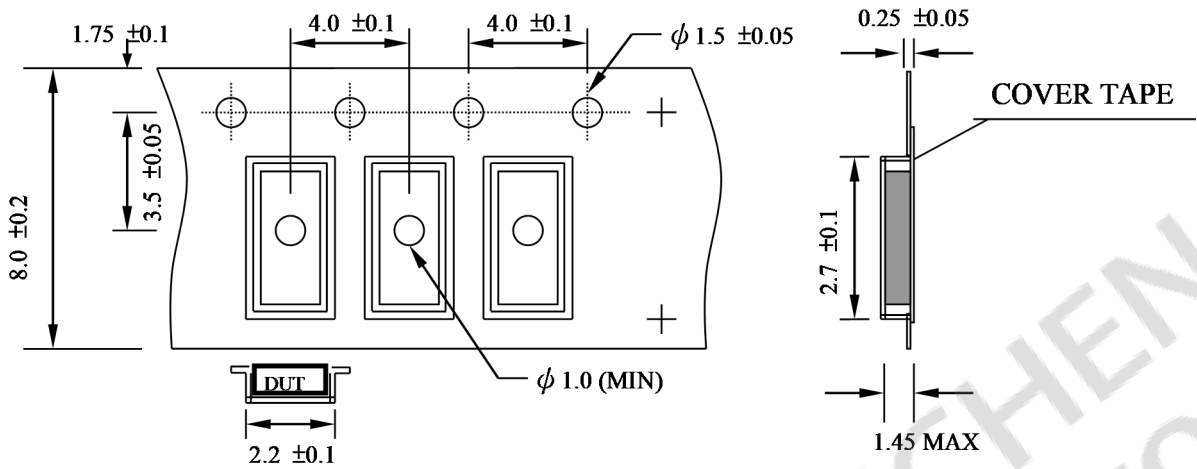

## Reel Packing(mm) :

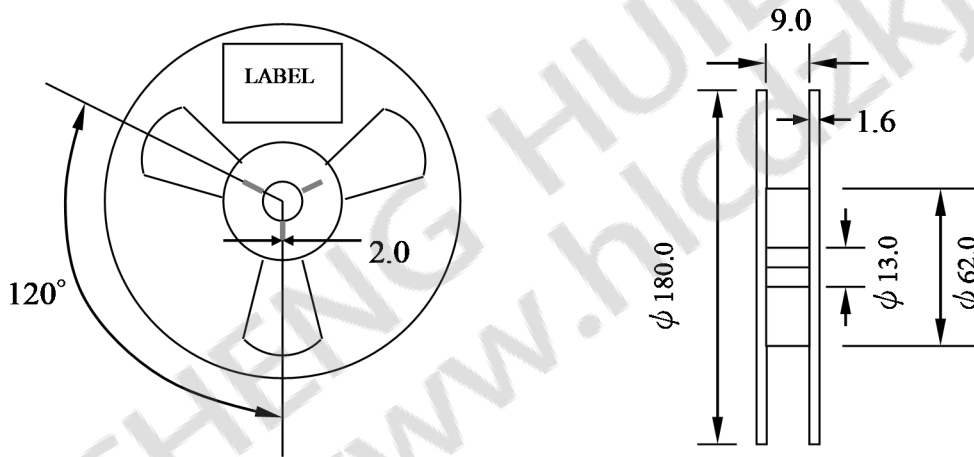

## Reflow Temperature Profile :

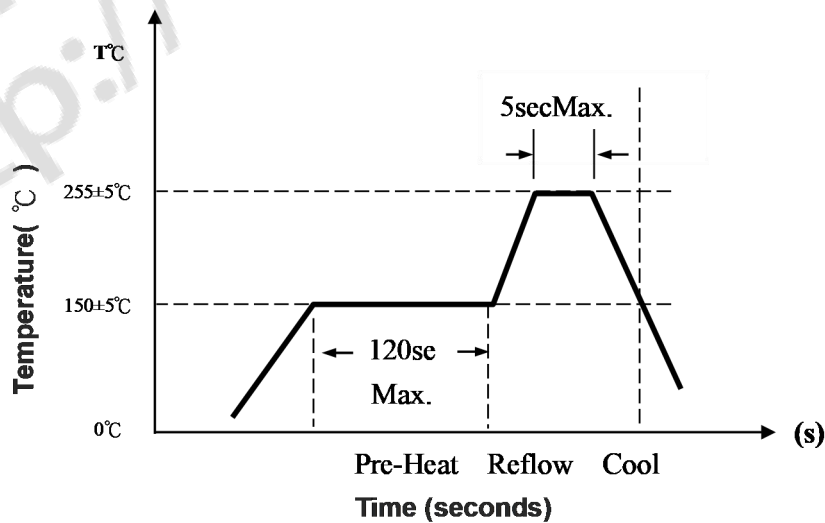

\* Above specification subject to change without prior notice, please consult our sales representative for more information\*

SHENZHEN - Shenzhen Huilicheng Electronic Technology Co.,Ltd. HONGKONG - HUILICHENG ELECTRONICS(HK)CO.,LIMITED

Address: 6910b,Seg Plaza,No.1002 North Huaqiang Road,Fuqiang Community,Huaqiang North Street,Shenzhen,Guangdong,China

Tel: +86-0755-83576022

E-mail: hlc-zzw@hlcdzjk.com

Fax: 0755-83778079

Web: <http://www.hlcdzjk.com>